

Recommended Installation Procedure For Kinedyne Steel Winch Track

Preparation of trailer for mounting of winch track, part number 3606

STEP 1

1. Winch track shall be positioned to underside of side rail, see **Figure 1**. The track shall extend past the side rail $1/4$ to $3/8$.
2. The backside of the track must be supported. This can be accomplished by welding angle iron or shims to the cross member flanges, see **Figure 1**, below. Angle iron may be sectioned to span every other cross member.

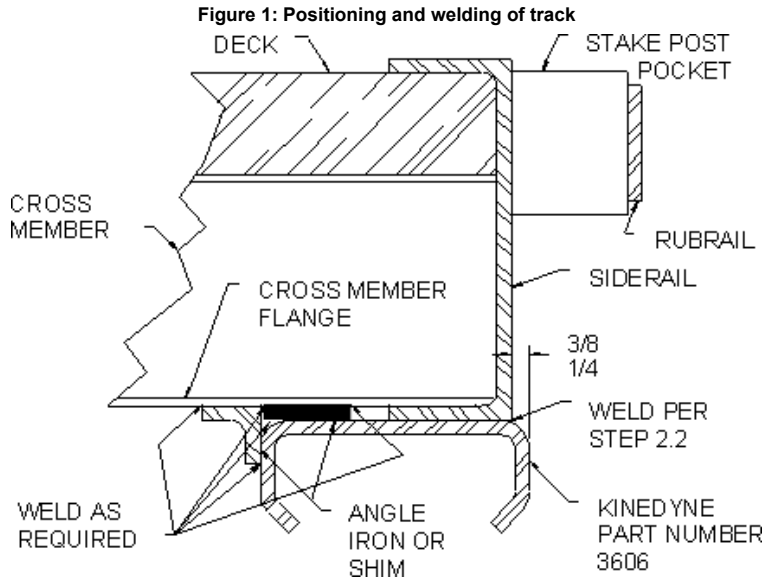

STEP 2 Install Track

- 1) Position track to underside of side rail as shown in **Figure 1**, above.
- 2) Weld track to side rail with $1/4$ -inch fillet welds 2 inches long every 6 inches with $1/8$ minimum penetration.
- 3) Weld track to angle iron or shims.

Preparation of trailer for mounting of winch track, part number 3607

Step 1: Drill and countersink track

1. Determine spacing and location of cross members on trailer.
2. Fasteners shall be placed at each cross member, 24 inch centers, maximum. Mark location of cross members on track.
3. Two fasteners are required at each cross member, see **Figure 1**, below, for layout of holes from centerline of track.
4. Drill and countersink track per **Figure 1**, below.

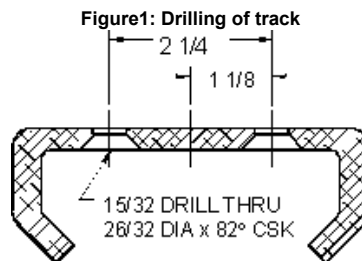

STEP 2 Install track

- 1) Position track, as shown in **Figure 2**. Place spacers, as required, between track and cross members so that the track will set flat across the cross members and side rail.

- 2) Clamp or hold track in place. Using the holes in the track as pilot holes, drill through the cross members and side rails as require
- 3) Install cap screws, washers and nuts. Torque nuts to 40 ft-lbs.

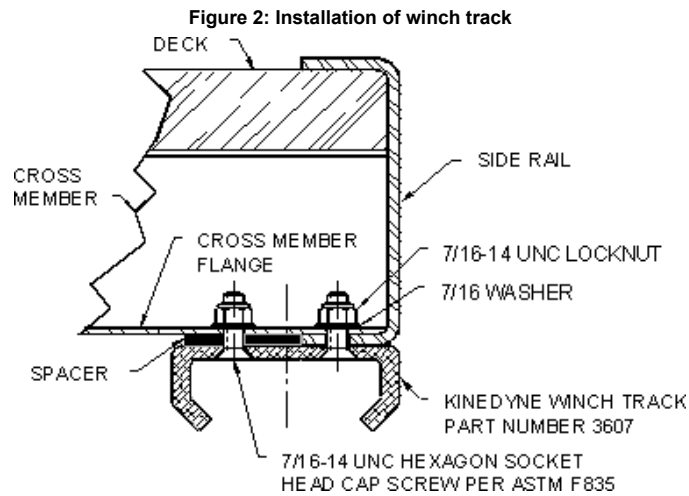

Preparation of trailer for mounting of winch track, part number 3608

STEP 1 Drill and countersink track

- 1) Determine spacing and location of cross members on trailer.
- 2) A fastener shall be placed at each cross member, 24-inch centers, maximum. Mark location of cross members on track
- 3) Drill and countersink track per **Figure 1**, below.

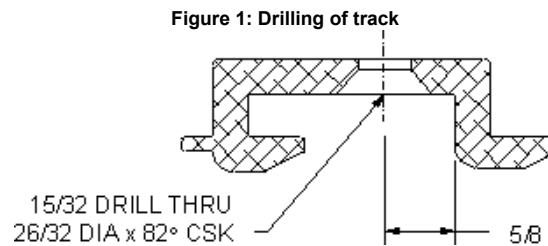

STEP 2 Install track

- 1) Position track, as shown in **Figure 2**.
- 2) Clamp or hold track in place. Using the holes in the track as pilot holes, drill through the cross members as required.
- 3) Install cap screws, washers and nuts. Torque nuts to 40 ft-lbs.

